

All stock items are available for **immediate shipment.**

Non-stock sizes of a round, oblong, square, hexagonal and rectangular shape of standard tooling will be **shipped within 48 hours.**

Model	Uses Punch	Uses Die
BF10, 350	BF10	H1
BFL 350 BFLH 400 HIW 450, 550, 600 HP 450 HPS 250, 350, 350E HPSN 350, 450, 500, 600 KBL 1/2, 0, 1-1/2, 48-4, 50-4, 71-5, 88-6, 560 KBLH 500, 700 KL 33, 350, 560, 750 KLH 500, 700 KLSH 550 MIW 400, 600, 800 PROFI 500	H1	H1
BULLDOG 65	H1	H2
HIW 1000 KBL 3-1/2, 110-7, 143-8, 900, 1300 KBLH 1000 KL 110, 143, 900, 1100, 1300 KLH 1000 KLS 1100 KLSH 1000	H2, H3	H2, H3
Oversize	H4, H5	H4, H5

Punches and Dies

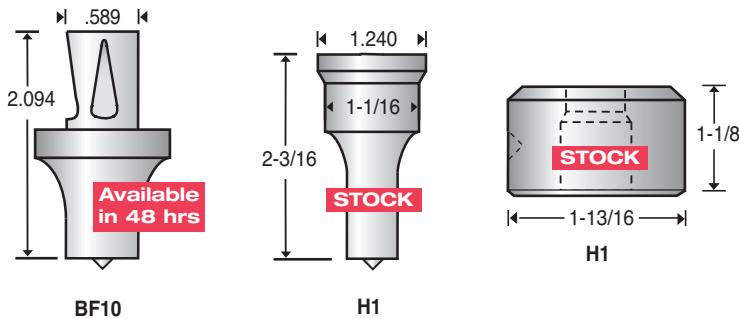

NOTE: H1 die is used with the BF10 punch.

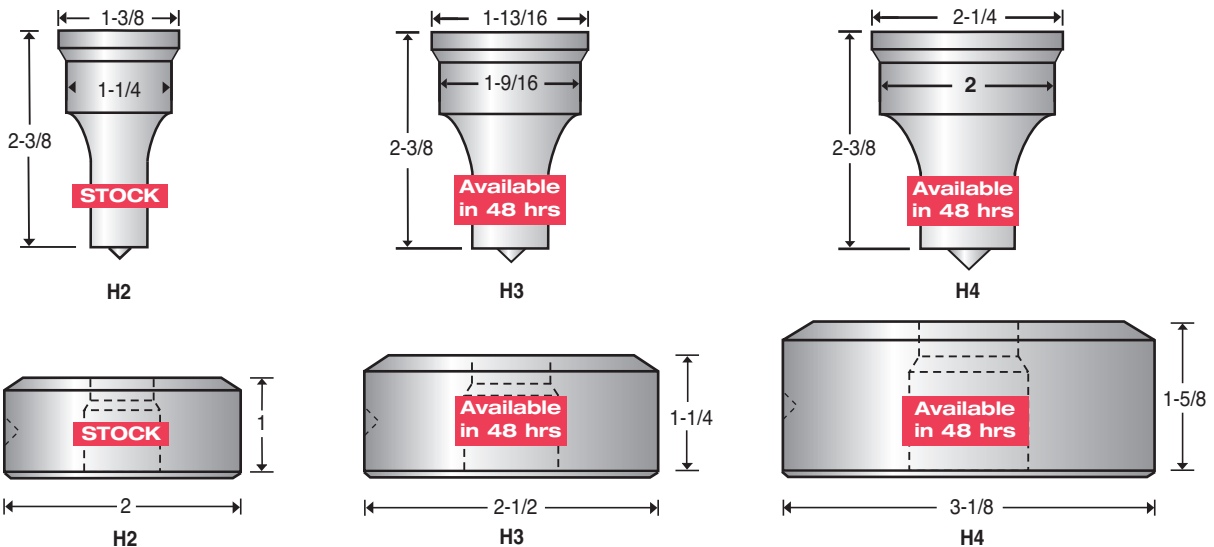

Punches and Dies

NOTE: Keyways and locating spots are recommended for alignment of shaped punches and dies. When ordering tooling, specify a Mubea Ironworker and a "V" groove keyway will be added to the head of shaped punches and set screw spots will be added to shaped dies. If no machinery is specified, keyways will not be furnished.

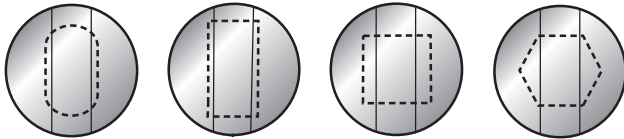

Standard Keyway Positions for Alignment of Shaped Punches

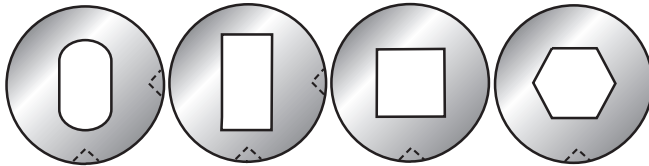
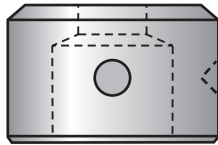

Standard Locating Spot Positions for Alignment of Shaped Dies

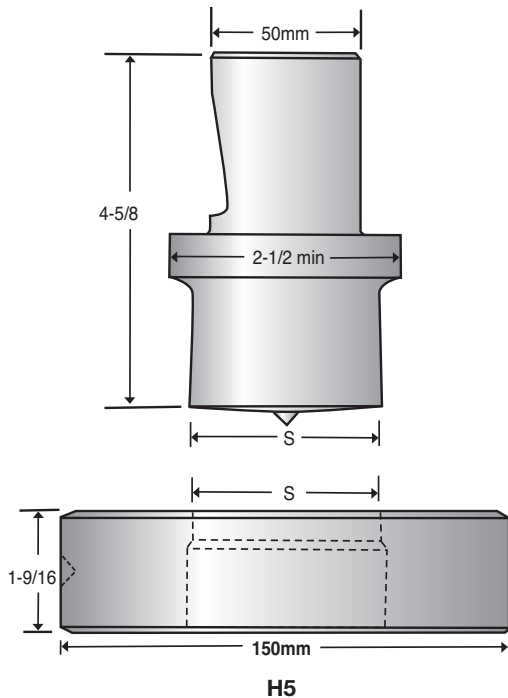

Stock Round Punch and Die Sizes

SIZE	BF10 PUNCH	H1		H2	
		PUNCH	DIE	PUNCH	DIE
7/32	●	●	●	●	●
1/4	●	●	●	●	●
9/32	●	●	●	●	●
5/16	●	●	●	●	●
11/32	●	●	●	●	●
3/8	●	●	●	●	●
13/32	●	●	●	●	●
7/16	●	●	●	●	●
15/32	●	●	●	●	●
1/2	●	●	●	●	●
17/32	●	●	●	●	●
9/16	●	●	●	●	●
19/32	●	●	●	●	●
5/8	●	●	●	●	●
21/32	●	●	●	●	●
11/16	●	●	●	●	●
23/32	●	●	●	●	●
3/4	●	●	●	●	●
25/32	●	●	●	●	●
13/16	●	●	●	●	●
27/32	●	●	●	●	●
7/8	●	●	●	●	●
29/32	●	●	●	●	●
15/16	●	●	●	●	●
31/32	●	●	●	●	●
1	●	●	●	●	●
1-1/32	●	●	●	●	●
1-1/16	●	●	●	●	●
1-1/8	●	●	●	●	●
1-3/16	●	●	●	●	●
1-1/4	●	●	●	●	●
1-5/16	●	●	●	●	●