

**WELDED FROM TWO SIDES**

**WELDED FROM ONE SIDE**

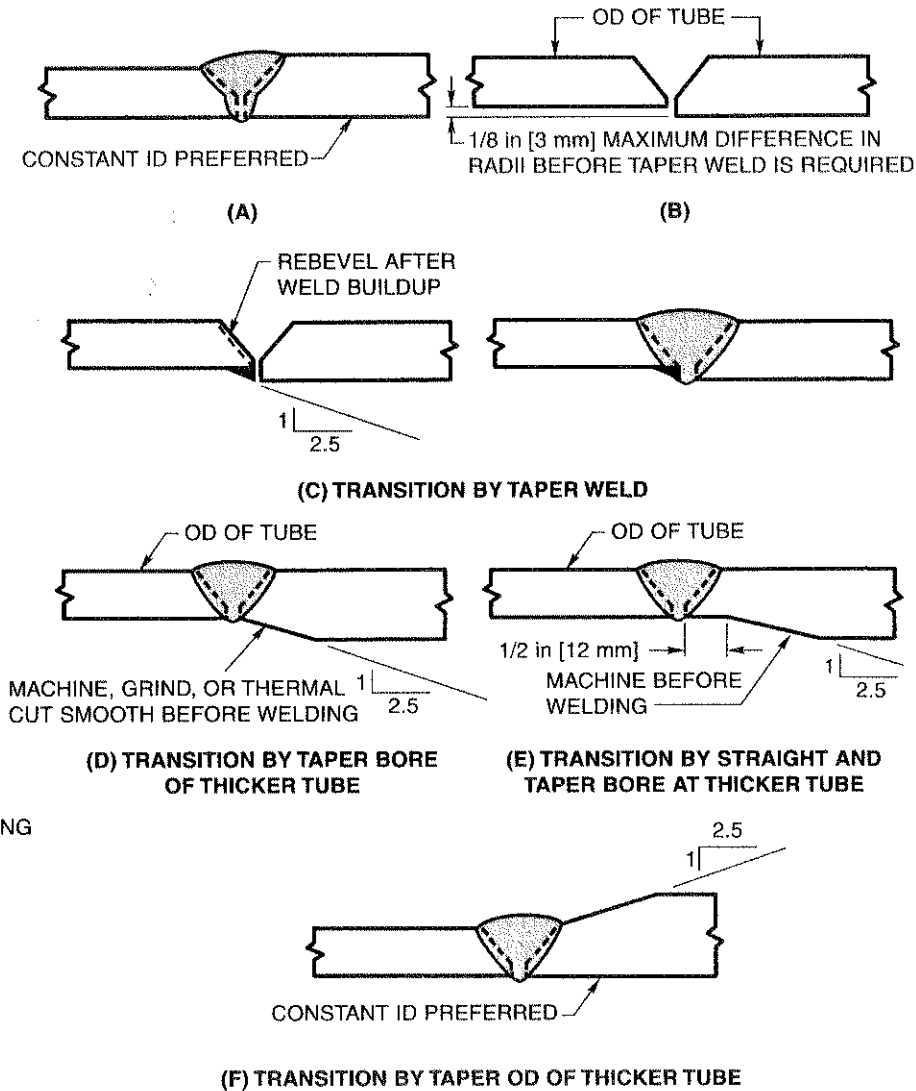
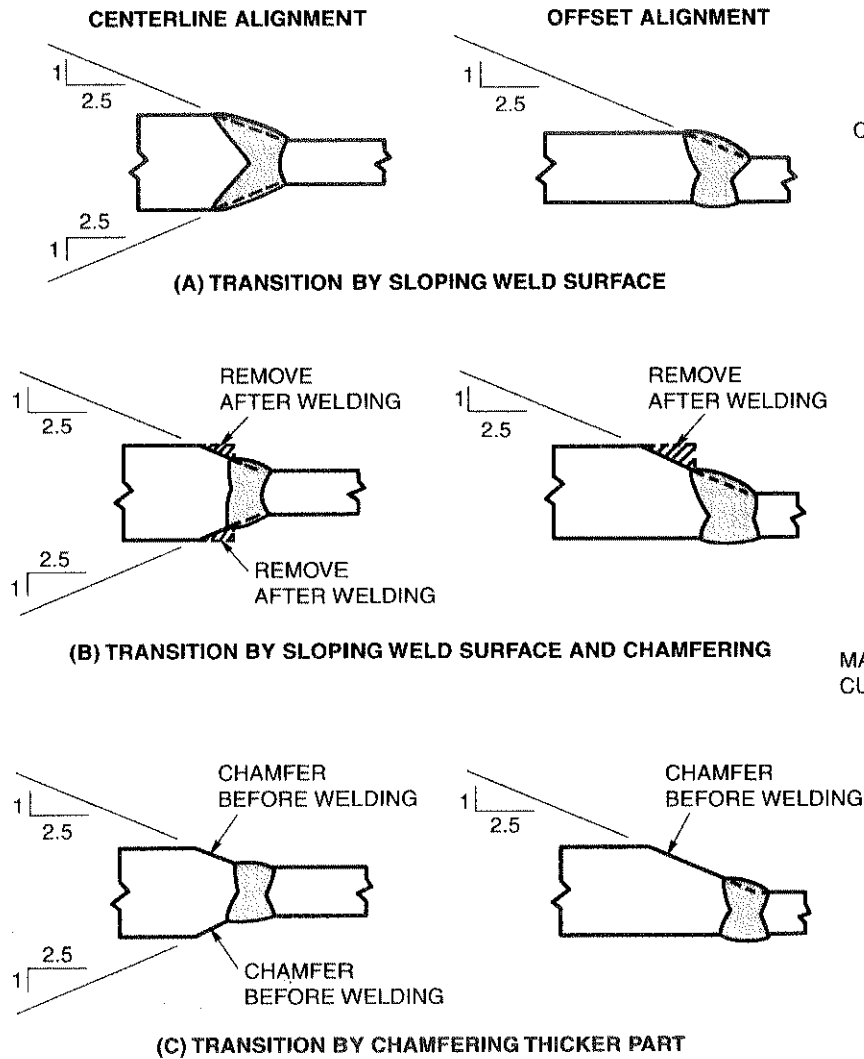

**Notes:**

1. Groove may be of any allowed or qualified type and detail.
2. Transition slopes shown are the maximum allowed.
3. In (B), (D), and (E) groove may be any allowed or qualified type and detail. Transition slopes shown are maximum allowed.

**Figure 2.21—Transition of Thickness of Butt Joints in Parts of Unequal Thickness (Tubular) (see 2.26)**