

2

1

MATERIAL LIST

ITEM	QTY	PART NUMBER	DESCRIPTION	WEIGHT
	1	B [REDACTED]	IDLER SHAFT, WELDED	[REDACTED]
1	1	A [REDACTED]	FLANGE PLATE	[REDACTED]
2	1	A [REDACTED]	IDLER SHAFT SAE1045	[REDACTED]
3	4	A [REDACTED]	GUSSET	[REDACTED]

B

A

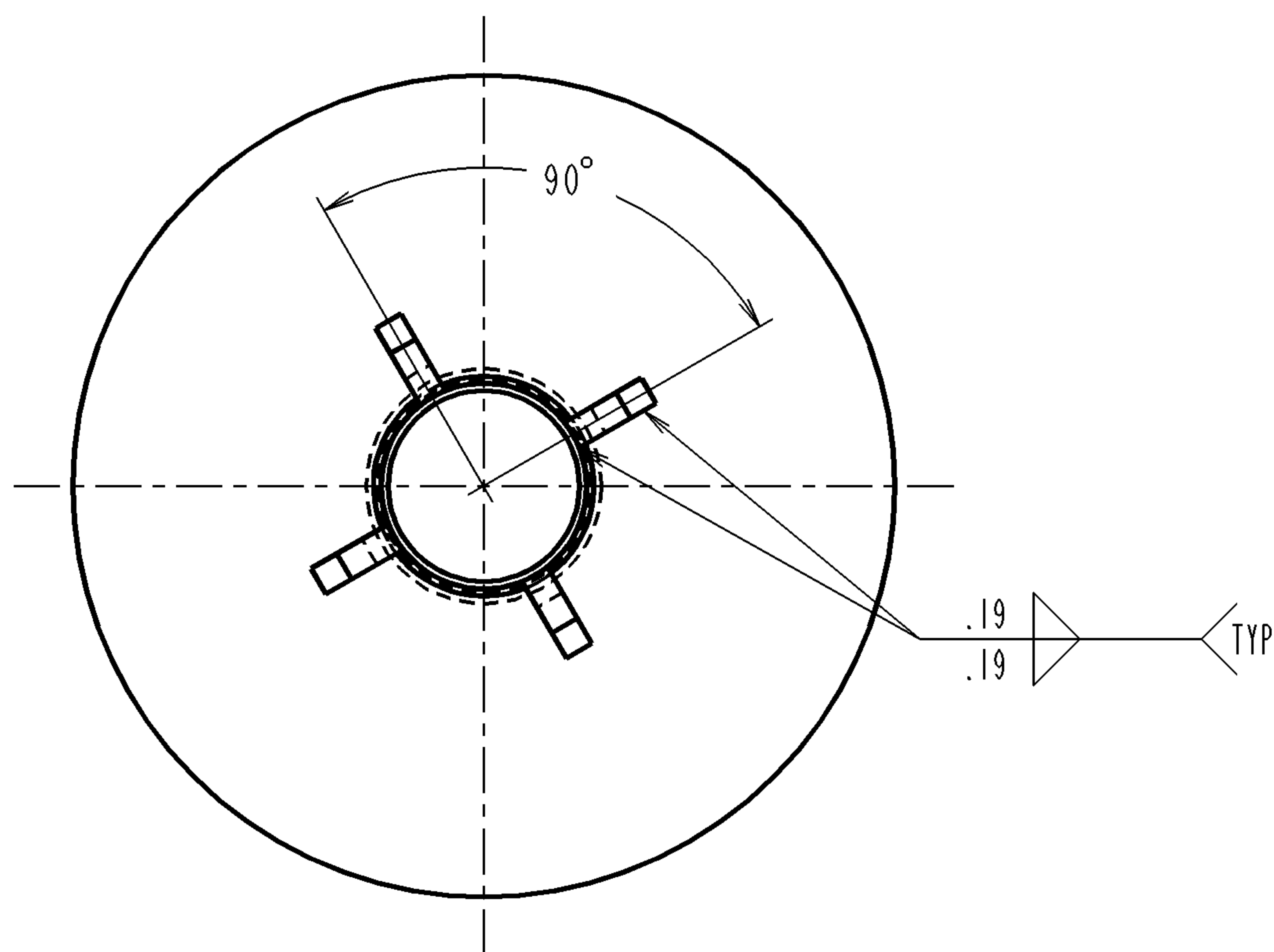
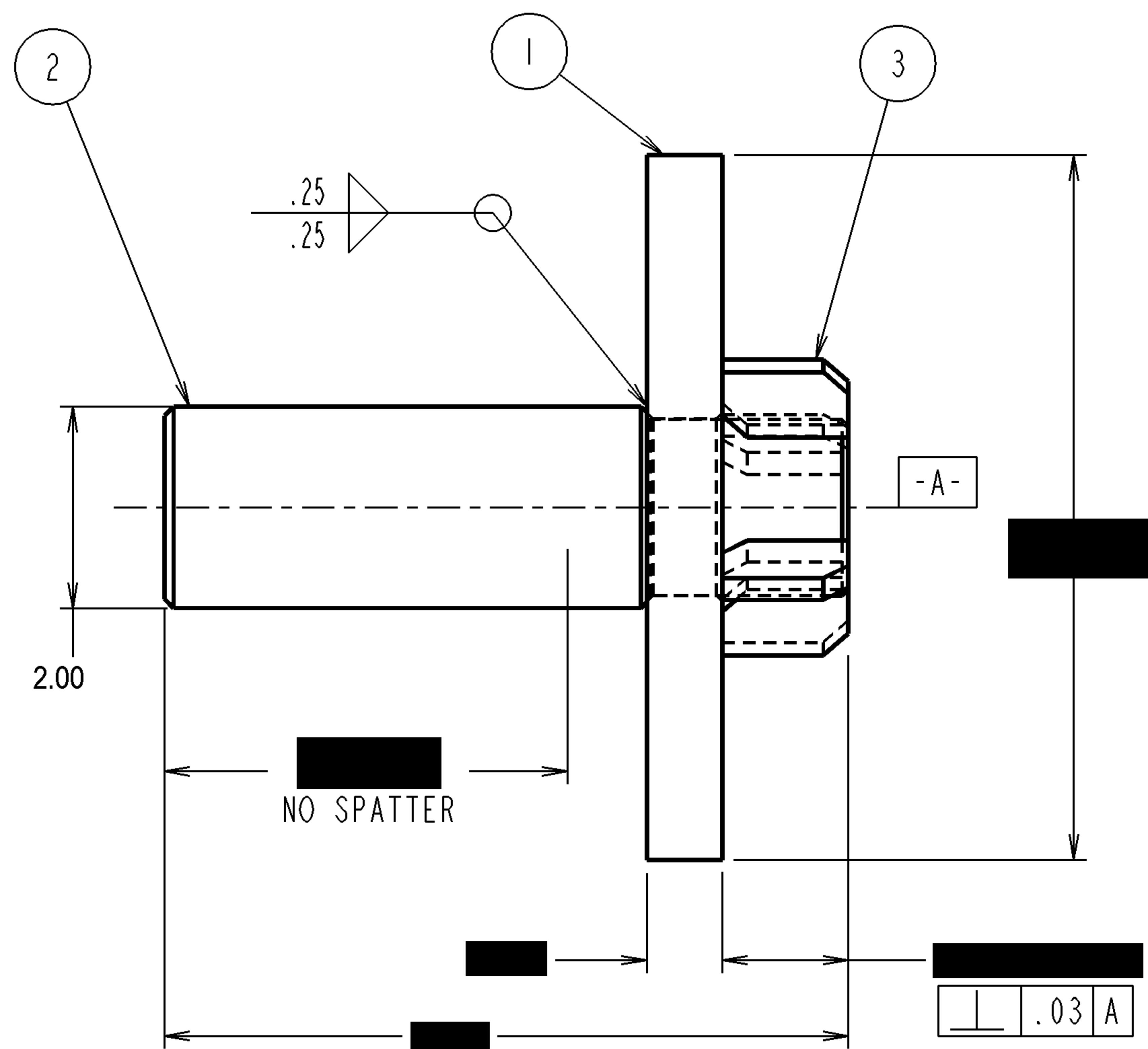

NOTE:
 PRE-HEAT SHAFT TO MIN. OF
 200°F BEFORE WELDING

REV BY : [REDACTED]	REV DATE : [REDACTED]	REV : [REDACTED]	RELEASE LEVEL : [REDACTED]	PRODUCTION
DWN BY : [REDACTED]	SCALE : [REDACTED]	IDLER SHAFT, WELDED		
CHKR :	DATE : [REDACTED]			
APVD BY :	3RD ANGLE PROJECTION			
ALL TOLERANCES PER [REDACTED]				
[REDACTED]		B [REDACTED]	SHT. 1/1	[REDACTED]

2

1

B

A