

(A) FLAT WELDING TEST POSITION—1F

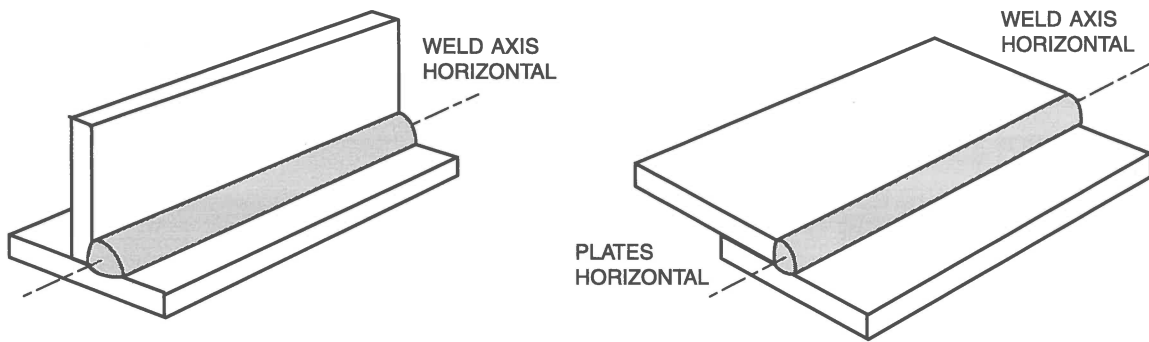

Note: One plate must be horizontal.

(B) HORIZONTAL WELDING TEST POSITION—2F

Figure B.18—Welding Test Positions and Their Designations for Fillet Welds in Plate